

Hand Expansion Valves

“Built Stronger to Last Longer”

Sizes: 6mm (1/4”) to 305mm (4”)

Suitable For: Ammonia, Fluorocarbons, Nitrogen and Carbon Dioxide

Features

- ASTM 352 LCB Cast Steel Body (1/4” thru 2”)
- Maximum Safe Working Pressure 400 PSIG
- Fluid Temperature Range: -60°F to +300°F
- Stainless Steel Stem
- Optional Stainless Steel Trim
- Reliable Back Seating
- Complete Line of Bolted Bonnets
- 25% Carbon Filled PTFE Seat (1/4” thru 2”)
- Available Connections:
 - 1/4” thru 1-1/2”, Screwed End
 - 1/4” thru 2”, Socket Weld
 - 1-1/4” thru 2”, Butt Weld
- “T” Pattern Globe Body For Easy Insulation
- Extended Bonnets For Thicker Insulation

Description

This complete line of all steel bodied valves with bolt-on bonnets are designed and built to maintain reliability both in their seating and back seating functions. This entire line is supplied with stainless steel stems and backseating capability. Corrosion resistant, high-grade stainless steel trim is available upon request. A unique carbon filled PTFE seat is standard throughout the line, lending durability to the seating surface. In addition a dual O-Ring stem packing design along with a stem packing seal is standard on all valves from 1/4” thru 2”. This innovative design seals both the valve stem and bonnet bore with independent O-Rings, which are captured in a carbon PTFE carrier. The addition of the packing provides for backup sealing capability in the unlikely event of an O-Ring failure.

A packing nut design with either 1/4” or 5/16” flats provide a generous wrench engagement area, with little likelihood of “rounding” the flat. With the O-Ring cartridge used in all valve bonnets, there will typically be no need to loosen the packing nut when opening or closing a valve. In most cases, stem

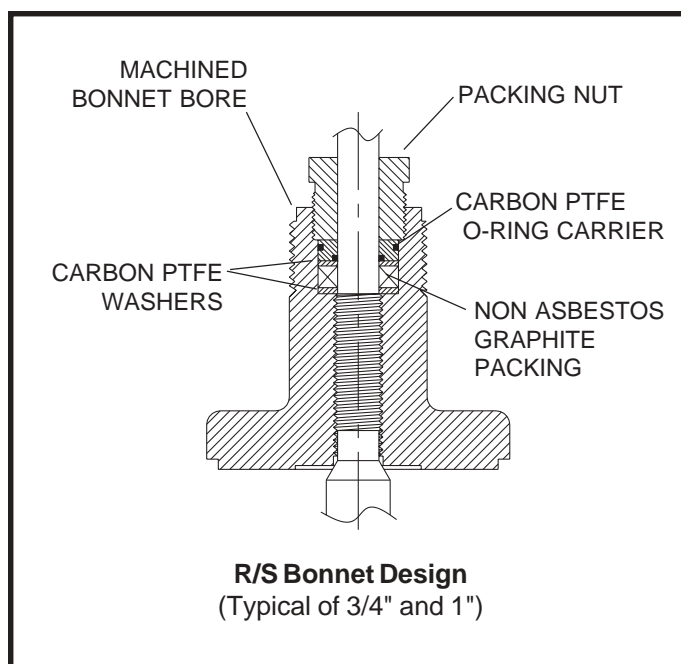

resistance will be negligible allowing the valve to be easily repositioned.

Note: The New Hand Expansion Valve plugs and Bonnet Assemblies will not retrofit to either a prior design hand expansion valve body or to a prior design stop valve.

The extended bonnet is available for globe style valves in the Tee body configuration and in angle style bodies. Bonnet bolts, extension boss boss clamp, packing nut, and stem are all of 300 series corrosion resistant stainless steels.

Screwed End (1/4" - 1-1/2") Angle

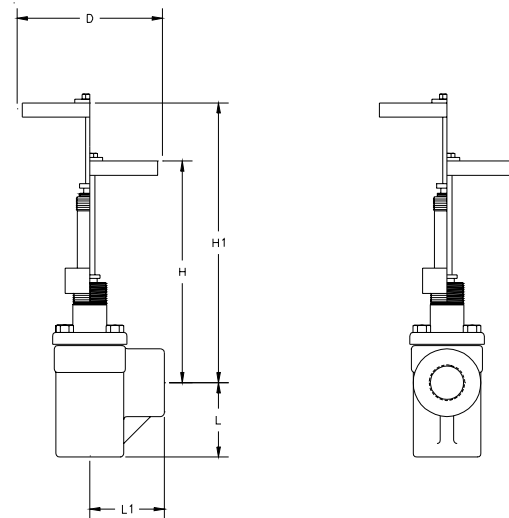
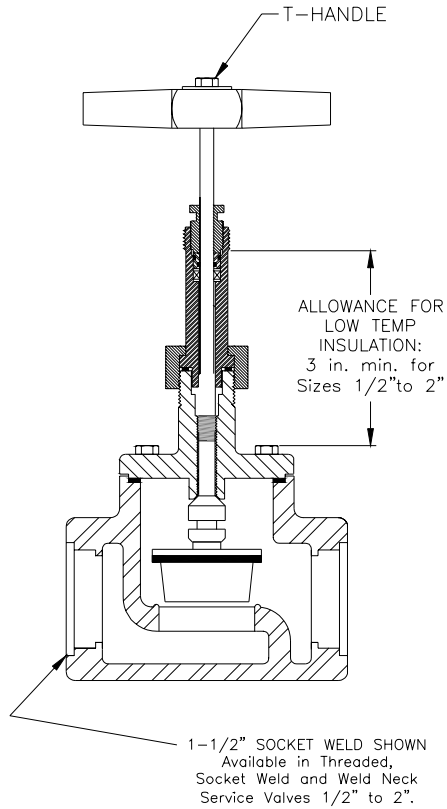

Screwed End Angle HEV Dimensions In Inches					
Valve Size	L	L1	H	H1	D
1/4" Angle	1.75	1.75	4.50	7.25	2.50
3/8" Angle	1.75	1.75	4.50	7.25	2.50
1/2" Angle	1.75	1.75	4.50	7.25	2.50
3/4" Angle	1.50	2.00	5.75	8.50	2.50
1" Angle	1.50	2.00	5.75	8.50	2.50
1-1/4" Angle	1.63	2.50	8.00	9.25	3.25
1-1/2" Angle	1.63	2.50	8.00	9.25	3.25

Screwed End (1/4" - 1-1/2") Globe

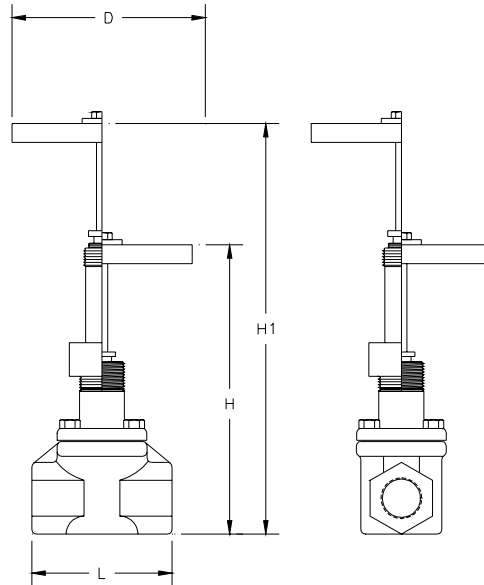

Screwed End Globe HEV Dimensions In Inches				
Valve Size	L	H	H1	D
1/4" Globe	3.75	5.75	7.25	2.50
3/8" Globe	3.75	5.75	7.25	2.50
1/2" Globe	3.75	5.75	7.25	2.50
3/4" Globe	3.88	5.75	8.50	2.50
1" Globe	3.88	5.75	8.50	2.50
1-1/4" Globe	5.00	8.00	9.25	3.25
1-1/2" Globe	5.00	8.00	9.25	3.25

Installation

Screwed End. The most important factor other than the valve itself in achieving a leak-tight and secure threaded valve installation is selection and preparation of mating piping. Pipe 1-1/2" and smaller should be Schedule 80 Steel ASTM A-106 Grade B or equal, properly cut to correct length and cleanly and properly threaded with U.S. National Tapered Male Pipe Threads. The male thread sealant is recommended. Sealant should be applied evenly to act as a lubricant between the threads to avoid any chance of metal to metal galling. Valve and piping should be adequately tightened with two wrenches positioned as close together as possible, but not touching the pipe threads. In horizontal piping of suction, overfeed gas return, or condenser drain lines, globe valve or angle valve stems should be horizontal to avoid liquid trapping of gas flow at the valve body casting seat orifice.

Before putting valves into service, all pipe connections, valve seats, bonnet seals and stem seals should be tested for leaks at pressure levels called for in appropriate codes

**SPARE PARTS FOR SCREWED END
HAND EXPANSION VALVES**

ITEM	DESCRIPTION	PORT SIZE						
		1/4"	3/8"	1/2"	3/4"	1"	1-1/4"	1-1/2"
1,2,4,7	Tee Handle	204265	204265	204265	204265	204265	204276	204276
1,2,4,7	SS Tee Handle	205712	205712	205712	205712	205712	205713	205713
9 -12,	Packing Kit	204471	204471	204471	204471	204471	204272	204272
9 -12, 16, 18	Plug Stem Kit Expansion	204309	204309	204309	204313	204313		
9 -12, 16, 18	SS Plug Stem Kit Expansion	205675	205675	205675	205679	205679	205680	205680
9- 16, 18	Bonnet Assembly	205697	205697	205697	205701	205701	205702	205702
9- 16, 18	Bonnet Assembly, Extended	205698	205698	205698	205972	205972	205973	205973
16	Gasket Pkg, Bonnet	204281	204281	204281	204282	204282	204283	204283
8	Gasket Pkg, Seal Cap	204292	204292	204292	204292	204292	204292	204292

Note: The New Hand Expansion Valve plugs and Bonnet Assemblies will not retrofit to either a prior design hand expansion valve body or to a prior design stop valve.

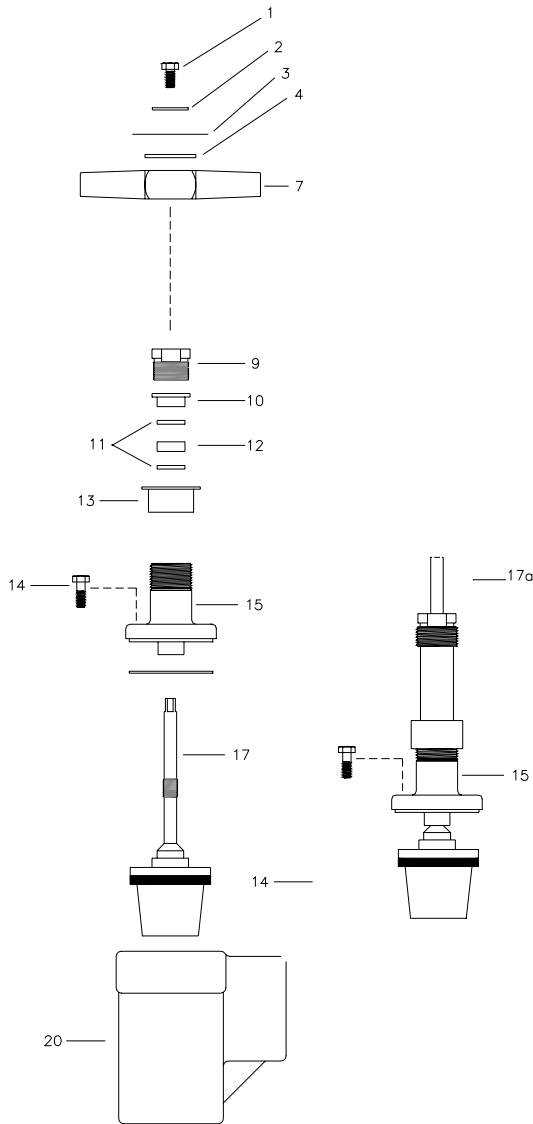

Item	Description
1	Screw, Cap
2	Lockwasher
3	Nameplate
4	Washer
5	Handwheel, std
5a	Handwheel, deep
6	Seal Cap
7	Tee Handle
8	Gasket, Seal Cap
9	Packing nut
10	O-ring carrier
11	Washer
12	Packing
13	Cap, Thread
14	Bolt
15	Bonnet
16	Gasket
17	Plug/Stem Asy
18	Plug/Stem Asy
19	Plug/Stem Asy
20	Body
21	Gasket
22	Seat Disc
23	Washer
24	Retainer

Socket Weld, Butt Weld. Welding valves may be installed in horizontal or vertical pipelines. Stems may be horizontal or vertical or angled upward. Globe valves in horizontal suction lines or liquid overfeed return lines, condenser drain lines, purge lines, oil pot drain lines and level control column isolation valves should preferably have stems horizontal rather than upward to avoid liquid or gas trapping at valve seat orifices. Inlet pressure for all valve sizes should normally be under valve seat disc.

The valve stem should be open during welding. Normally it is not necessary to disassemble valves for welding. However, if welding is prolonged enough to overheat the body, a wet rag should be wrapped around the valve bonnet and upper body during welding. The codes applicable to the welding of socket weld valves require that the pipe be inserted into the socket until bottomed against the stop. The pipe is then to be backed out approximately 1/16 of an inch before welding.

Use of welding rings is optional but recommended for butt weld valves. They help alignment, control gap for full penetration welding and reduce welding debris entry. Welds should be annealed as necessary in accordance with good practice. Painting of valves and welds is recommended for corrosion protection. Pipe covering where applied, should have proper moisture barrier.

Shut-off valves leading to the atmosphere, even if it is temporary, must be plugged or capped to prevent corrosion inside of the valve as well as leakage due to vibration, pressure shock, or improper opening; the valve seat should be cracked open to prevent hydrostatic expansion between the valve and the cap. Valves should never directly feed a water tank because of potential internal corrosion or seat opening caused by vibration.

Before putting valves into service, all pipe connections, valve seats, bonnet seals and stem seals should be tested for leaks at pressure levels called for in appropriate codes

Socket Weld (1/4" - 4") Angle

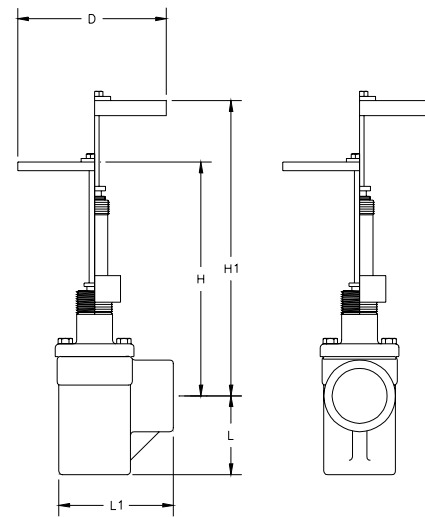

Socket Weld Angle HEV Dimensions In Inches					
Valve Size	L	L1	H	H1	D
1/4" Angle	1.75	1.75	4.50	7.25	2.50
3/8" Angle	1.75	1.75	4.50	7.25	2.50
1/2" Angle	1.75	1.75	4.50	7.25	2.50
3/4" Angle	1.50	2.00	5.75	8.50	2.50
1" Angle	1.50	2.00	5.75	8.50	2.50
1-1/4" Angle	2.75	2.75	7.88	9.00	3.25
1-1/2" Angle	2.75	2.75	7.88	9.00	3.25
2" Angle	3.12	3.12	8.38	10.25	3.25

Socket Weld (1/4" - 2-1/2") Globe T

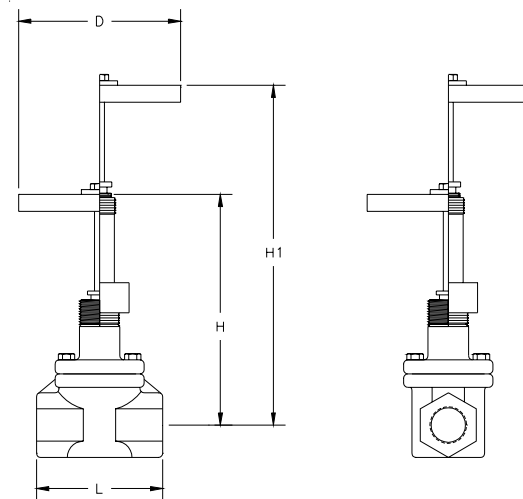

Socket Weld Globe HEV Dimensions In Inches				
Valve Size	L	H	H1	D
1/4" Globe	3.75	5.75	7.25	2.50
3/8" Globe	3.75	5.75	7.25	2.50
1/2" Globe	3.75	5.75	7.25	2.50
3/4" Globe	3.88	5.75	8.50	2.50
1" Globe	3.88	5.75	8.50	2.50
1-1/4" Globe	7.00	8.88	9.00	3.25
1-1/2" Globe	8.25	10.00	9.00	3.25
2" Globe	8.25	10.00	10.25	3.25

		SPARE PARTS FOR SOCKET WELD							
		HAND EXPANSION VALVES							
		PORT SIZE							
ITEM	DESCRIPTION	1/4"	3/8"	1/2"	3/4"	1"	1-1/4"	1-1/2"	2"
1,2,4,7	Tee Handle	204265	204265	204265	204265	204265	204276	204276	204276
1,2,4,7	SS Tee Handle	205712	205712	205712	205712	205712	205713	205713	205713
6,8	Cap Kit, Seal	204273	204273	204273	204273	204273	204274	204274	204274
9 -12,	Packing Kit	204471	204471	204471	204471	204471	204472	204472	204472
9 -12,16,17	Plug Stem Kit, Expansion	204309	204309	204309	204313	204313	204315	204315	204316
9 -12,16,17	SS Plug Stem Kit, Expansion	205675	205675	205675	205679	205679	205681	205682	205682
9-16. 17	Bonnet Assembly Expansion	205697	205698	205699	205700	205701	205703	205703	205704
9-16. 17a	Bonnet Assembly Extended	205968	205968	205968	205972	205972	205973	205973	205974
16	Gasket Pkg, Bonnet	204281	204281	204281	204282	204282	204283	204283	204284
8	Gasket Pkg, Seal Cap	204292	204292	204292	204292	204292	204292	204292	204292

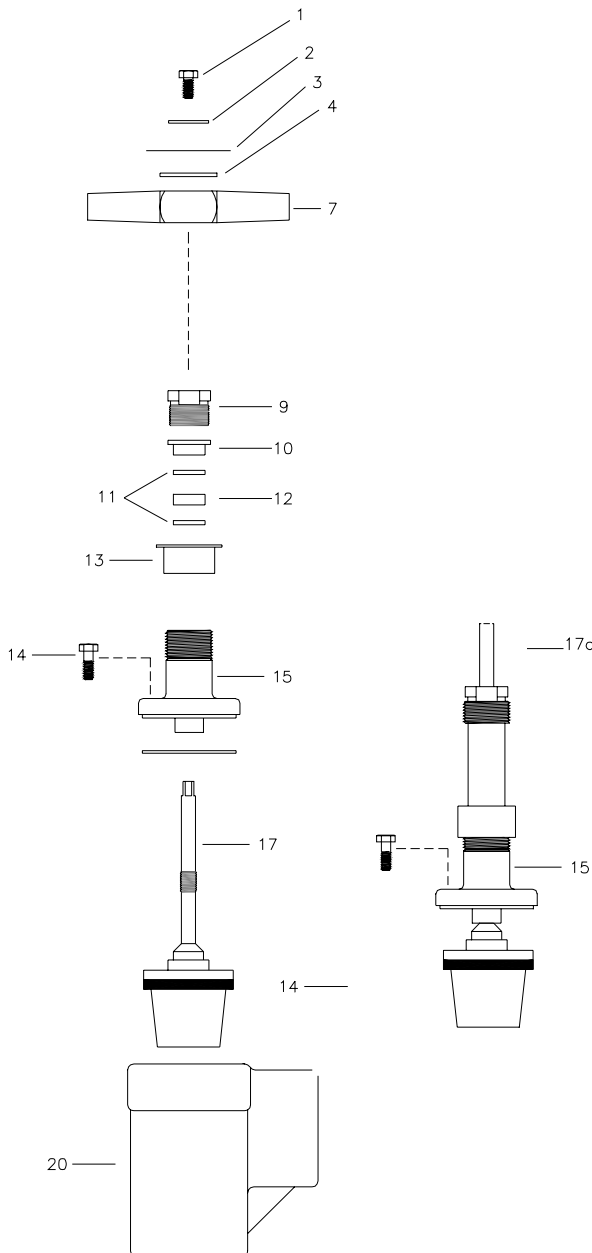

Item	Description
1	Screw, Cap
2	Lockwasher
3	Nameplate
4	Washer
5	Handwheel, std
5a	Handwheel, deep
6	Seal Cap
7	Tee Handle
8	Gasket, Seal Cap
9	Packing nut
10	O-ring carrier
11	Washer
12	Packing
13	Cap, Thread
14	Bolt
15	Bonnet
16	Gasket
17	Plug/Stem Asy
18	Plug/Stem Asy
19	Plug/Stem Asy
20	Body
21	Gasket
22	Seat Disc
23	Washer
24	Retainer

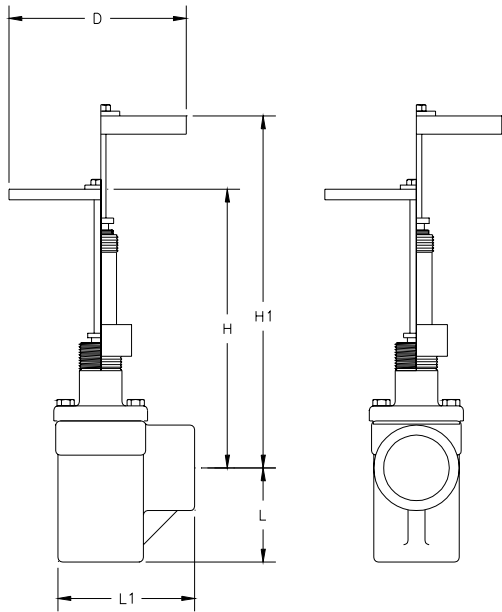

Butt Weld (1-1/4" - 12") Angle

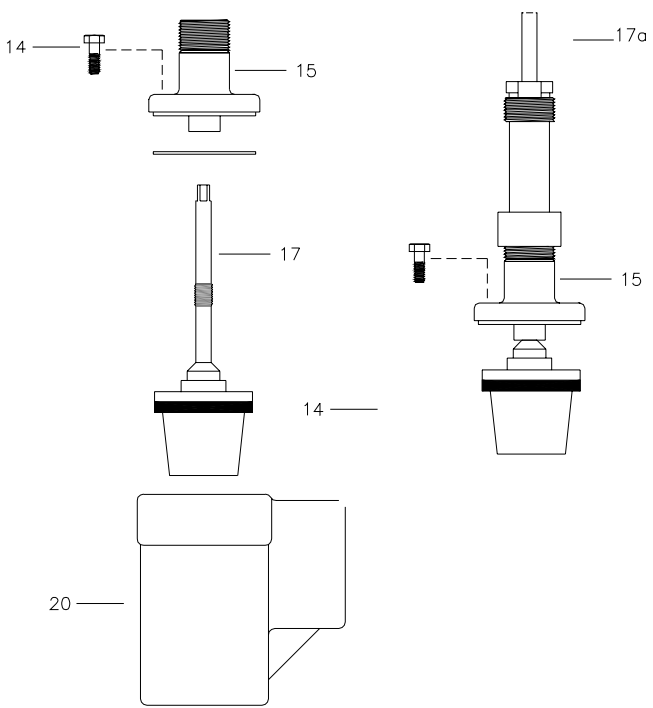
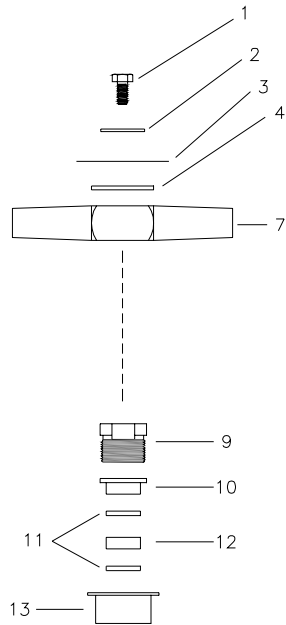

Butt Weld Angle HEV Dimensions In Inches					
Valve Size	L	L1	H	H1	D
1-1/4" Angle	2.75	2.75	7.75	10.50	3.25
1-1/2" Angle	2.63	2.63	8.12	10.50	3.25
2" Angle	3.00	3.00	8.50	11.00	3.25

Item	Description
1	Screw, Cap
2	Lockwasher
3	Nameplate
4	Washer
5	Handwheel, std
5a	Handwheel, deep
6	Seal Cap
7	Tee Handle
8	Gasket, Seal Cap
9	Packing nut
10	O-ring carrier
11	Washer
12	Packing
13	Cap, Thread
14	Bolt
15	Bonnet
16	Gasket
17	Plug/Stem Asy
18	Plug/Stem Asy
19	Plug/Stem Asy
20	Body
21	Gasket
22	Seat Disc
23	Washer
24	Retainer

SPARE PARTS FOR BUTT WELD HAND EXPANSION VALVES				
ITEM	DESCRIPTION	PORT SIZE		
		1-1/4"	1-1/2"	2"
1,2,4,7	Tee Handle	204276	204276	204276
1,2,4,7	SS Tee Handle	205713	205713	205713
9 -12,	Packing Kit	204472	204472	204472
9 -12,16,17	Plug Stem Kit, Expansion	204315	204315	204316
9 -12,16,17	SS Plug Stem Kit, Expansion	205681	205681	205682
9-16, 17a	Bonnet Assembly Expansion	205703	205703	205704
9- 16, 18	Bonnet Assembly, Extended	205973	205973	205974
16	Gasket Pkg, Bonnet	204283	204283	204284
8	Gasket Pkg, Seal Cap	204292	204292	204292

Safe Operation (See also Bulletin RSB)

People doing any work on a refrigeration system must be qualified and completely familiar with the system and the Refrigerating Specialties Division valves involved, or all other precautions will be meaningless. This includes reading and understanding pertinent Refrigerating Specialties Division product Bulletins and Safety Bulletin RSB prior to installation or servicing work.

Where cold refrigerant liquid lines are used, it is necessary that certain precautions be taken to avoid damage that could result from liquid expansion. Temperature increase in a piping section full of solid liquid will cause high pressure due to the expanding liquid that can possibly rupture a gasket, pipe or valve. All hand valves isolating such sections should be marked, warning against accidental closing, and must not be closed until the liquid is removed. Check valves must never be installed upstream of solenoid valves, or regulators with electric shut-off, nor should hand valve upstream of solenoid valves or downstream of check valves be close until the liquid has been removed. It is advisable to properly install relief devices in any section where liquid expansion could take place.

Avoid all piping or control arrangements that might produce thermal or pressure shock. For the protection of people and products, all refrigerant must be removed from the section to be worked on before a valve, strainer, or other device is opened or removed. Flanges with ODS connections are not suitable for ammonia service.

Warranty

All Refrigerating Specialties products are warranted against defects in workmanship and materials for a period of one year from date of shipment from originating factory. This warranty is in force only when products are properly installed, field assembled, maintained, and operated in use and service as specifically stated in Refrigerating Specialties Catalogs or Bulletins for normal refrigeration applications, unless otherwise approved in writing by Refrigerating Specialties Division. Defective products, or parts thereof returned to the factory with transportation charges prepaid and found to be defective by factory inspection will be replaced or repaired at Refrigerating Specialties option, free of charge F.O.B. factory. Warranty does not cover products that have been altered, or repaired in the field; damaged in transit, accidents, misuse, or abuse. Products disabled by dirt or other foreign substances will not be considered defective. The express warranty above constitutes the only warranty of Refrigerating Specialties products, and is in lieu of all other warranties, expressed or implied, written or oral, including any warranty of merchantability or warranty of fitness for a particular purpose and in no event is Refrigerating Specialties responsible for any consequential damages of any nature whatsoever. No employee, agent, dealer or other person is authorized to give any warranties on behalf of Refrigerating Specialties nor to assume for Refrigerating Specialties any other liability in connection with any of its products.

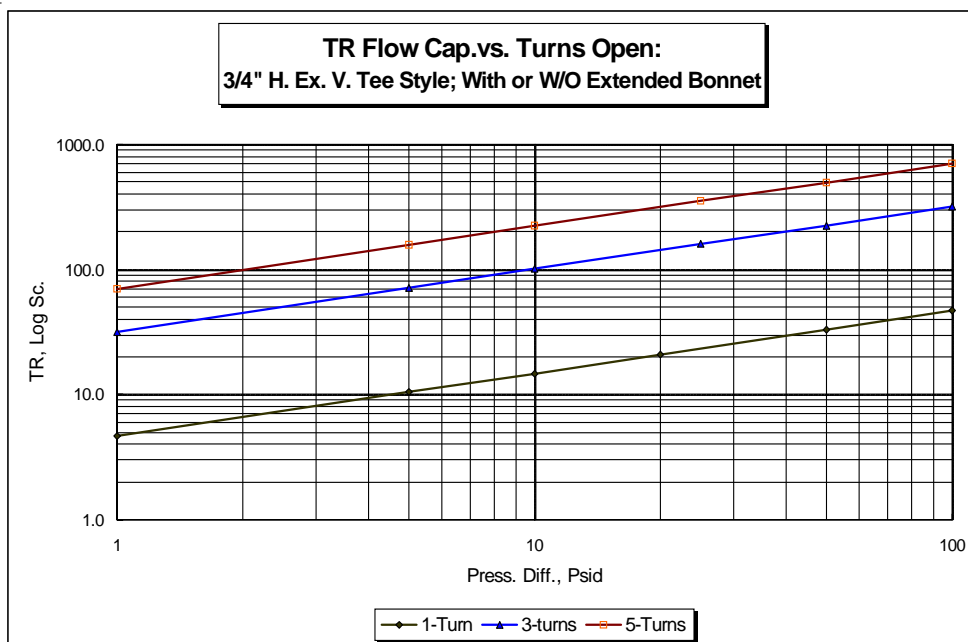
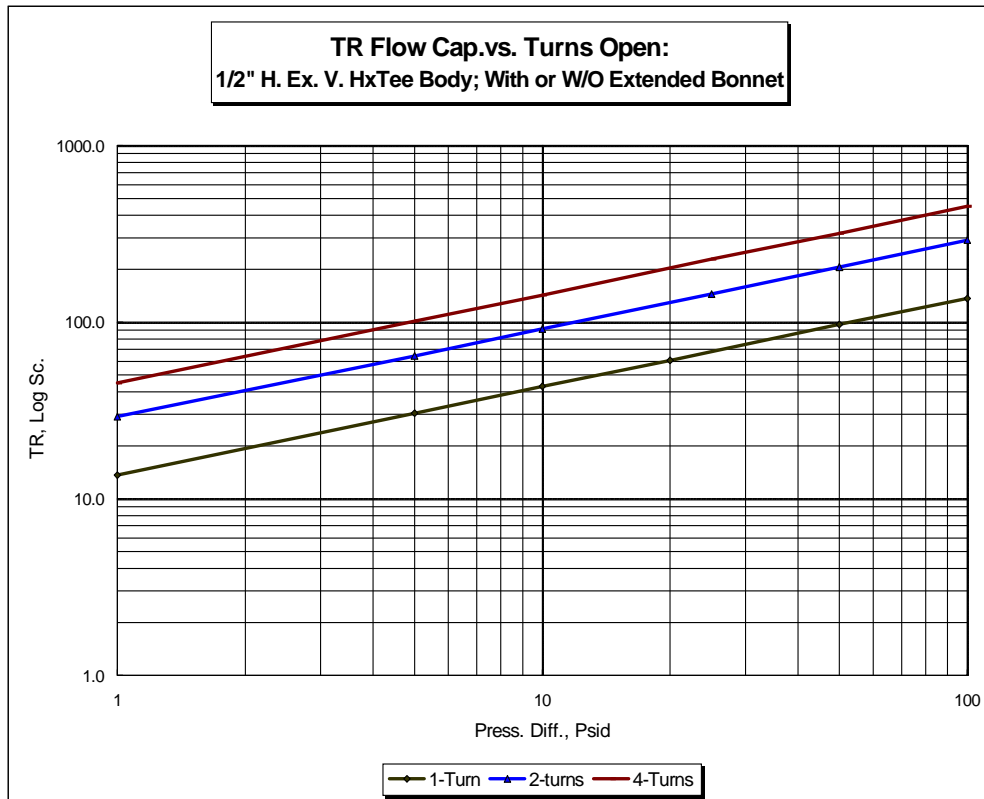

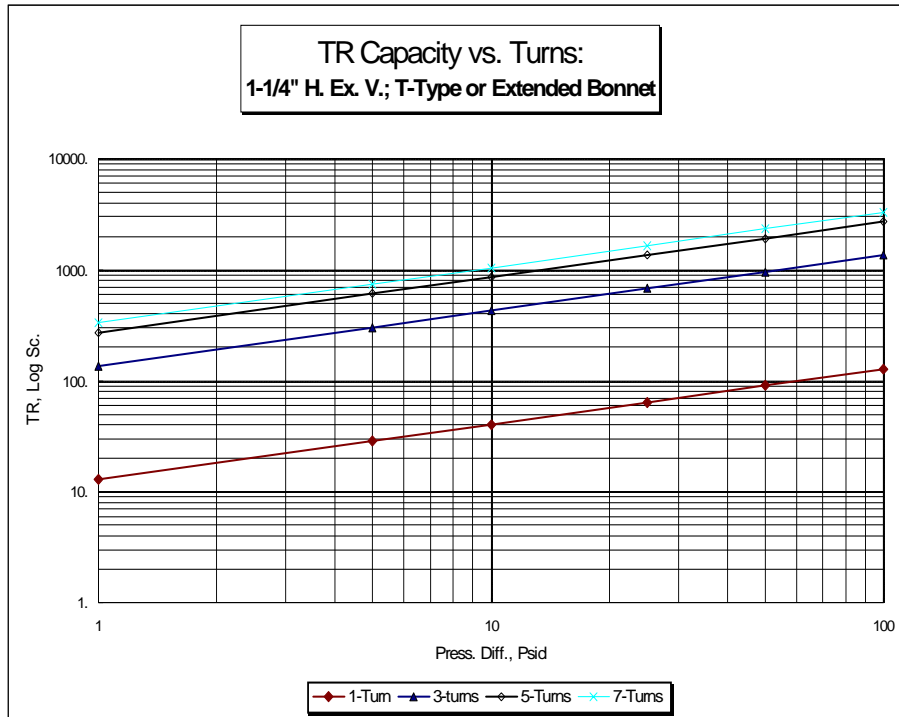
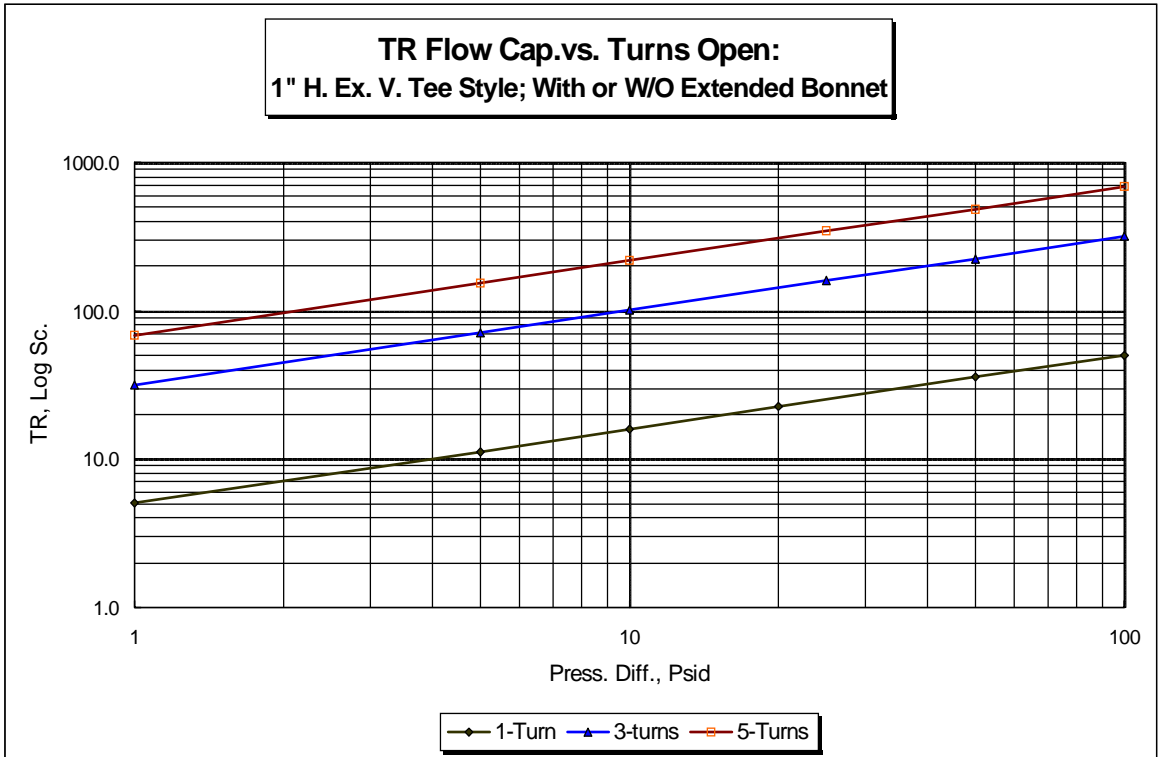

**TR Capacity vs. Turns:
1-1/2" H. Ex. V.; T-Type or Extended Bonnet**

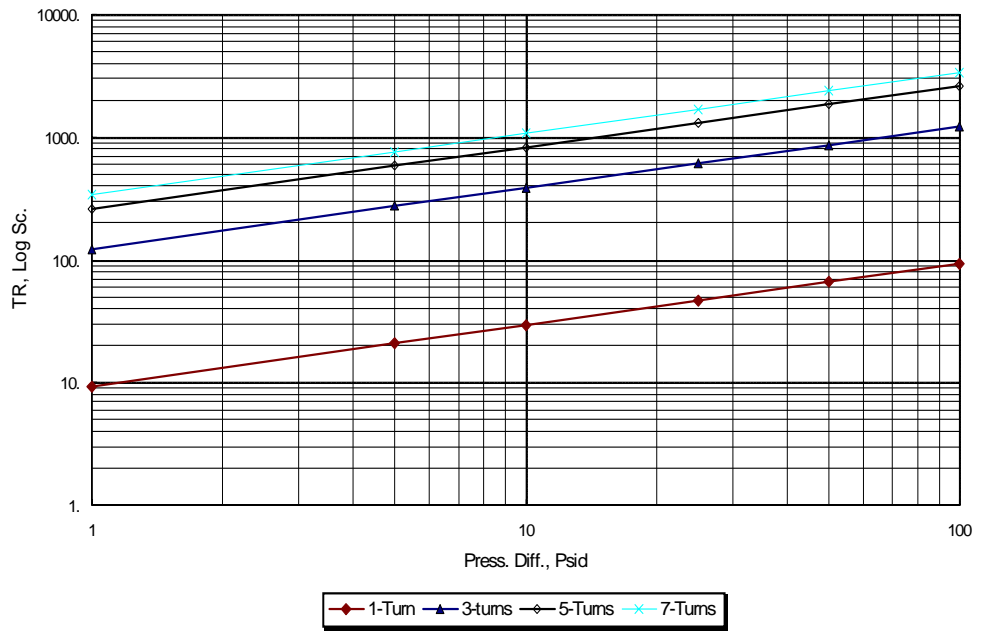

REFRIGERATING SPECIALTIES HAND VALVE SPECIFICATIONS						
FLOW PATH	GLOBE	ANGLE	GLOBE	ANGLE	GLOBE	ANGLE
Connections	Threaded & S.W.		Threaded & S.W.		S.W. & B.W.	
Sizes	1/4", 3/8", 1/2"		3/4", 1", 1-1/4", 1-1/2"		2"	
Bonnet Type	Forged Steel		Forged Steel		Ductile Iron	
Body Materials	Cast Steel		Cast Steel		Cast Steel	
Packing Materials	Non-Asbestos Graphite		Non-Asbestos Graphite		Non-Asbestos Graphite	
Seat Materials	25% Carbon Filled PTFE		25% Carbon Filled PTFE		25% Carbon Filled PTFE	

TORQUE REQUIREMENTS		
BOLT DIAMETER	VALVE PORT SIZE	TORQUE
5/16" (8mm)	1/4" - 1/2" (6 - 13mm)	11.0 ft lb (1.5 mkg)
5/16" (8mm)	3/4" - 1" (20 - 25mm)	12.5 ft lb (1.7 mkg)
3/8" (9.5mm)	1-1/4" - 1-1/2" (32 - 38mm)	20.8 ft lb (2.9 mkg)
7/16" (11mm)	2" (50mm)	25.0 ft lb (3.5 mkg)
PACKING NUT	VALVE PORT SIZE	TORQUE
	1/4"- 4" (6 - 100mm)	2.5 ft lb (0.3 mkg)

